



Caldaiastufa idro a pellet a modulazione di combustione automatica per il riscaldamento domestico combinato aria-acqua.

Pellet water stove with automatic modulation of combustion for the domestic heating combined air-water.

Collegabile ad ogni impianto di distribuzione esistente - Rivestimento in maiolica disponibile in 4 colori - Porta rivestita in cristallo - Ventilazione ambiente inclusa - Scambiatore di calore in rame brevettato "L'utilizzo di fasci tubieri in rame costituisce, il principale elemento di pregio rispetto ai prodotti similari offerti dalle aziende competitor (.....) le vantaggiose proprietà di cui gode, quali la resistenza alla corrosione e le ottime caratteristiche di conducibilità termica." **Dalla Ricerca condotta presso il Dipartimento di Meccanica dell'Università della Calabria.** - Sistema di pulizia facilitato brevettato - Accensione e spegnimento programmabili - Produzione acqua calda sanitaria in continuo (optional).

Connectable to any existing water heating system - External facing of ceramic available in 4 colours - Door external facing of crystal - Ambience ventilation included - Patented water heat exchanger of copper - Patented simplify exchanger cleaning system - Programmable turning on and off - Production of continuous hot drinking water (optional).

An jede bereits bestehende Verteileranlage anzuschließen - Keramikverkleidung in 4 verschiedenen Farben - Tür mit Kristallglas verkleidet - Raumbelüftung inbegriffen - Patentierter Wärmetauscher aus Kupfer - Patentiertes Reinigungssystem - Programmierbares Ein und Ausschalten - Kontinuierliche Warmwasserproduktion (optional).

Il se connecte à n'importe quel système de distribution existant - Revêtement en céramique disponible en 4 couleurs - Porte avec façade en verre - Ventilateur ambience inclus - Echangeur de chaleur en cuivre breveté - Système nettoyage facilité breveté - Démarrages et arrêts programmables - Production d'eau chaude en continu (optionnel).

Posible conexión a cualquier instalación de distribución existente - Revestimiento en cerámica disponible en 4 colores - Puerta revestida de cristal - Sistema de ventilación incluido - Intercambiador de calor de cobre patentado - Sistema de fácil limpieza patentado - Programación del encendido y apagado disponible - Producción continua de agua caliente sanitaria (opcional).



Avorio
Ivory

Ocra
Ochra

Bordeaux
Bordeaux

Cuoio
Leather



Fra parentesi valori con ventilazione ambiente spenta
In brackets values with ambience fan off

Maia Classic

18 kW

Potenza termica Heat Input	Max	kW	19,5 (19,5)
	Min	kW	5,5 (5,5)
Potenza nominale Nominal heat	Max	kW	18,1 (18,0)
	Min	kW	5,2 (5,2)
Rendimento Efficiency	Max	%	92,4 (92,1)
	Min	%	95,6 (95,7)
Potenza all'acqua Water heat output	Max	kW	13,1 (14,0)
	Min	kW	3,7 (3,9)
Potenza all'aria Space heat output	Max	kW	5,0 (4,0)
	Min	kW	1,6 (1,3)
Capacità serbatoio Tank capacity		kg	25,0
Consumo orario pellet Hourly pellet consumption	Max	kg	3,9
	Min	kg	1,1
Autonomia di lavoro Working autonomy	Max	h	23
	Min	h	6
Superficie riscaldabile Heatable surface		m ²	120
Uscita scarico fumi pellet Pellet smoke outlet		Ø mm	80,0
Tiraggio Max Draft	Max	Pa	12,0
	Min	Pa	11,0
Entrata aria comburente pellet Pellet primary air inlet		Ø mm	50,0
Prevalenza circolatore Water circulator prevalence		m	5,0
Pressione di utilizzo a freddo Pressure on cold working mode		bar	0,8/1,2
Dimensione vaso di espansione Expansion vase size		l	6,0
Produzione acqua calda sanitaria (optional) Hot drinking water production (option)		lt/min	9,0
Tensione di alimentazione Working voltage supply			220 V - 50 Hz
Assorbimento elettrico in fase di lavoro Electric absorbment in working mode		Watt	160,0
Peso Weight		kg	152,0

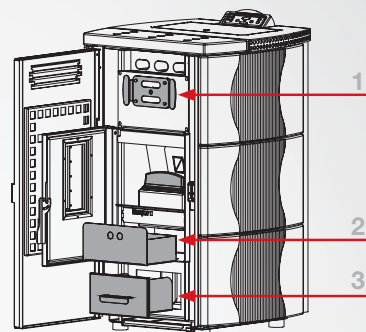

- 1 Sistema pulizia facilitato BREVETTATO
Patented simplify exchanger cleaning system
- 2 Cassetto cenere principale
Main ash drawer
- 3 Cassetto cenere secondario
Lower ash drawer

